

SOMA™ 6351/6352

LIFT DESK

INSTRUCTION MANUAL

LET'S GET STARTED.

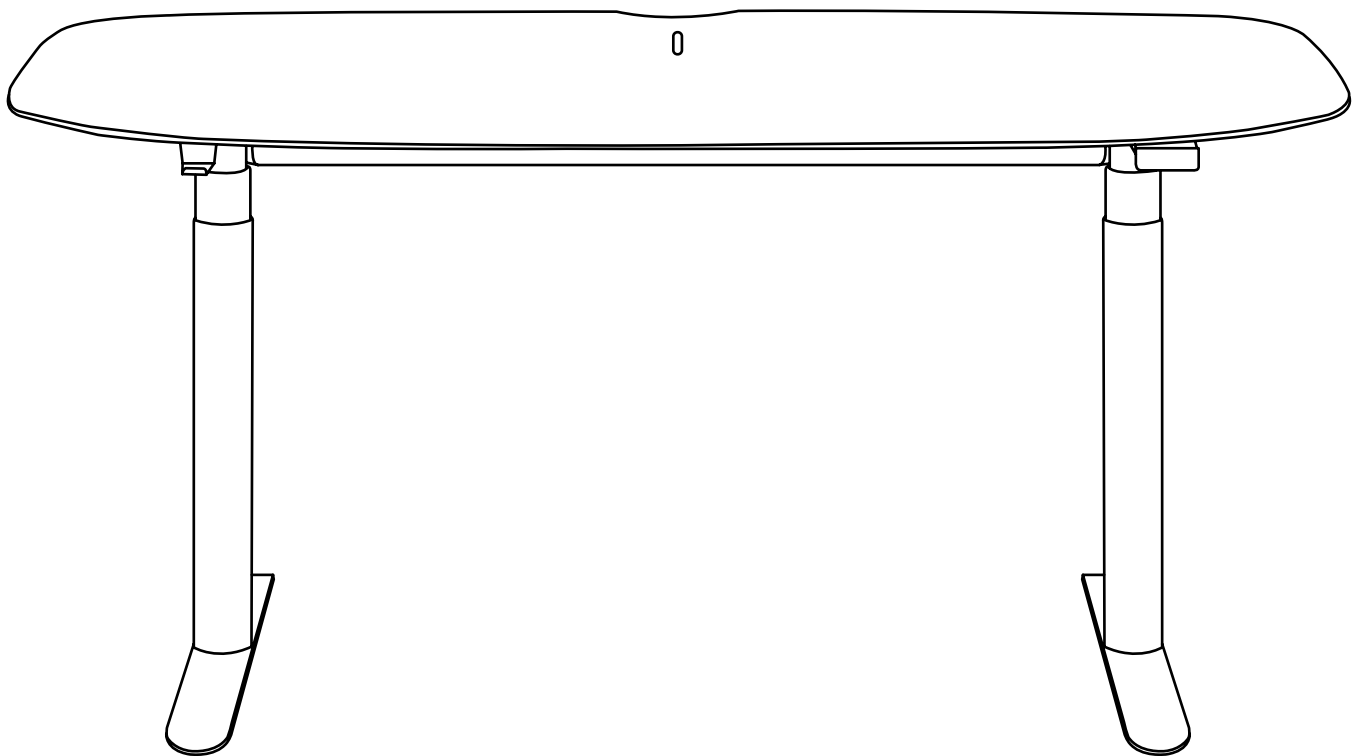

DESIGN JEFF BARE

BDi

BDIUSA.COM

Congratulations on the purchase of your Soma Lift Desk from BDI. Your lift desk has been designed to provide a lifetime of enjoyment. This manual will provide you with assembly instructions and other helpful information to ensure you get the most out of your product. Please save it for future reference.

Your Soma Lift Desk has been engineered for simple assembly. Please follow these directions carefully to prevent any damage.

Should you need further assistance, contact BDI at customerservice@bdiusa.com.

ENJOY!



HARDWARE AND COMPONENTS

Unpack and identify the parts listed below. The assembly workspace should be a non-marring surface, such as carpet. For missing hardware pieces, please contact BDI Customer Service at customerservice@bdiusa.com.

Do not use power tools for the assembly of this product.

For all other concerns, please contact your BDI retailer.



Hex Wrench (T1)

QTY: 1

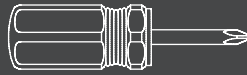

Phillips Screwdriver

TOOL REQUIRED (NOT INCLUDED)

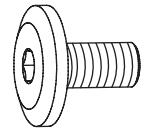

M6 x 12 Screw (H1)

QTY: 16

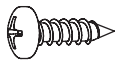

Wood Screw #6 x .5" (H2)

QTY: 4

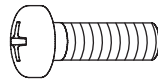

M5 x 16 Screw (H3)

QTY: 6

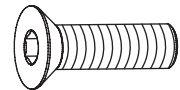

M6 x 20 Screw (H4)

QTY: 8

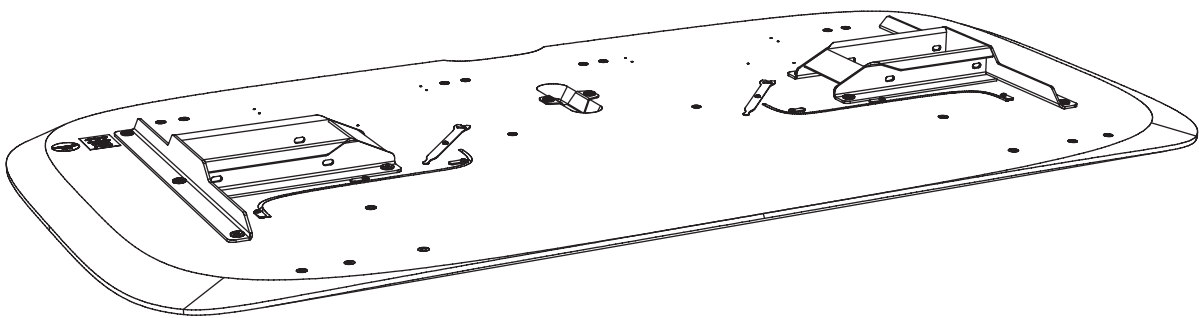

Top Panel (C1)

QTY: 1

HARDWARE AND COMPONENTS

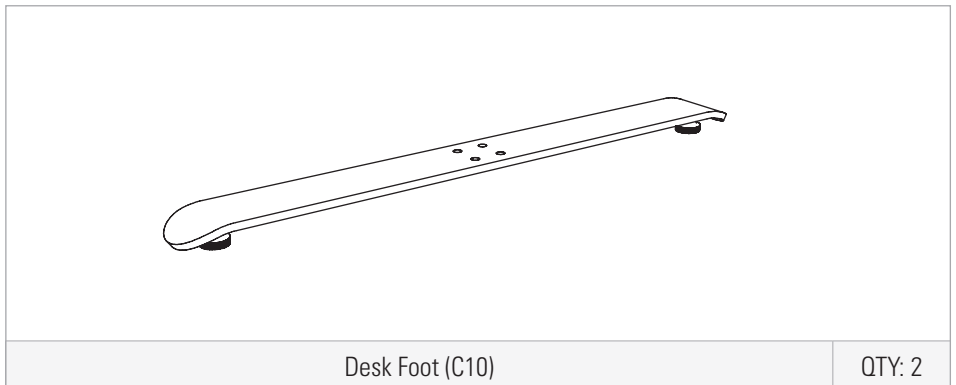
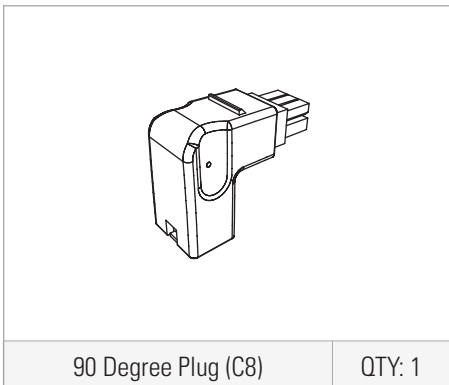
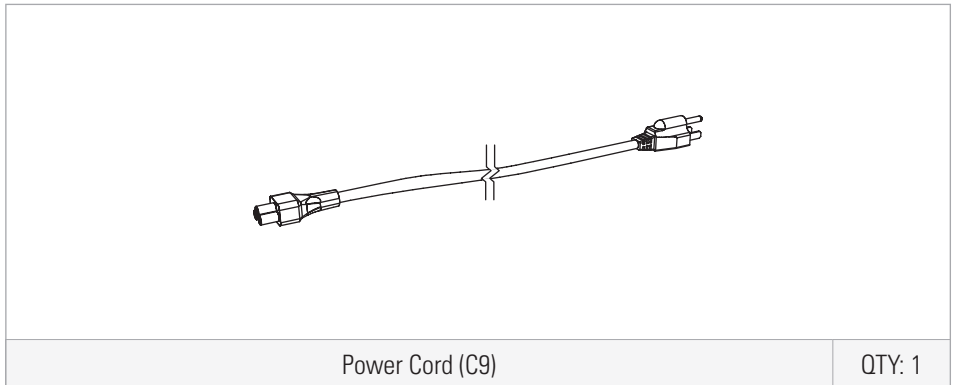
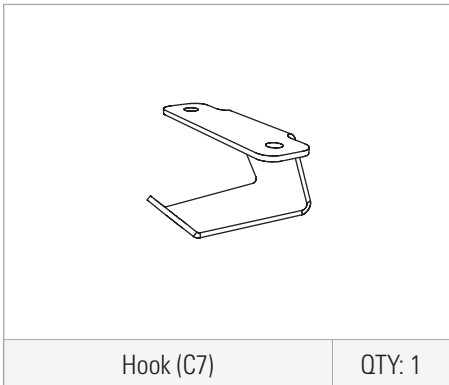
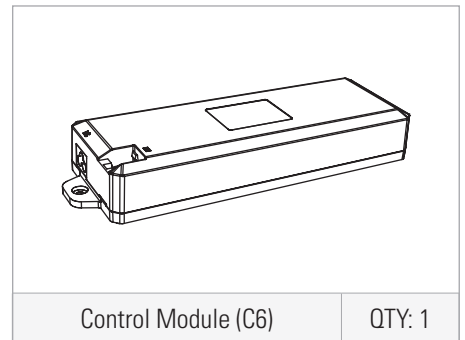
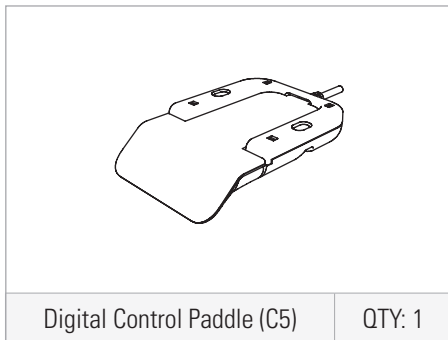
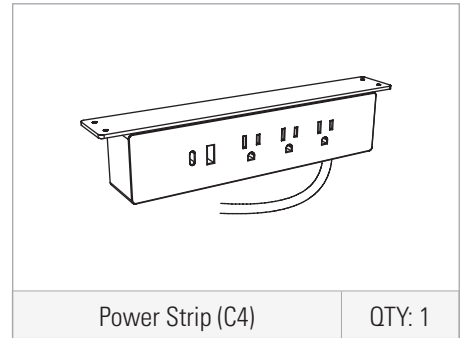
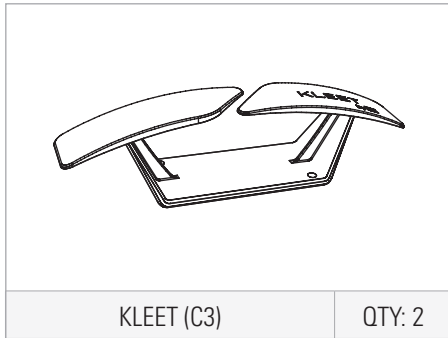
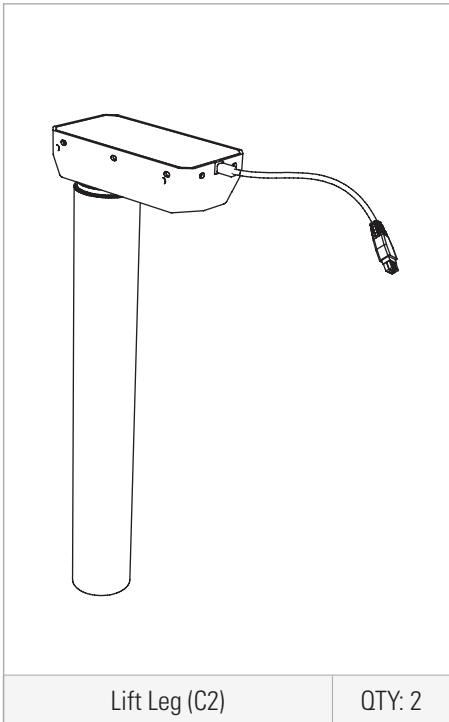

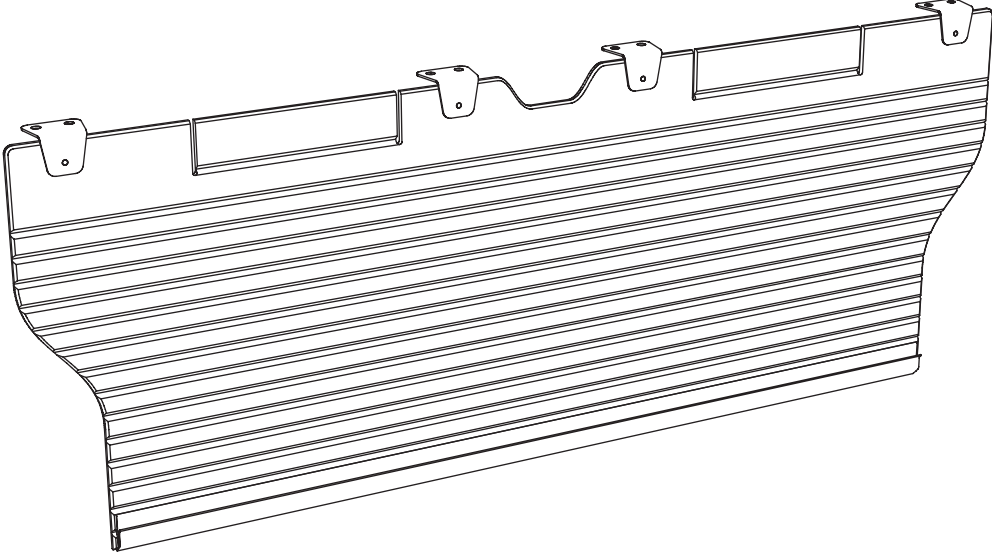

Wire Cradle (C11)

QTY: 1

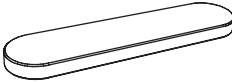



Grommet Lid (C12)

QTY: 1

Lay the **Top Panel (C1)** upside down on a soft, non-marring surface like carpet.

Position **2 Lift Legs (C2)** inside the metal frames, lining up the mounting holes on the legs with the slotted holes in the metal frame. Route the wires under the frame crossbar.

Attach the **2 Lift Legs (C2)** to the metal frames using **8 Screws (H1)** and tighten with the **Hex Wrench (T1)**. Start all screws before tightening.

	DESCRIPTION – PART #	QTY
	HEX WRENCH – T1	1
	SCREW – H1	8

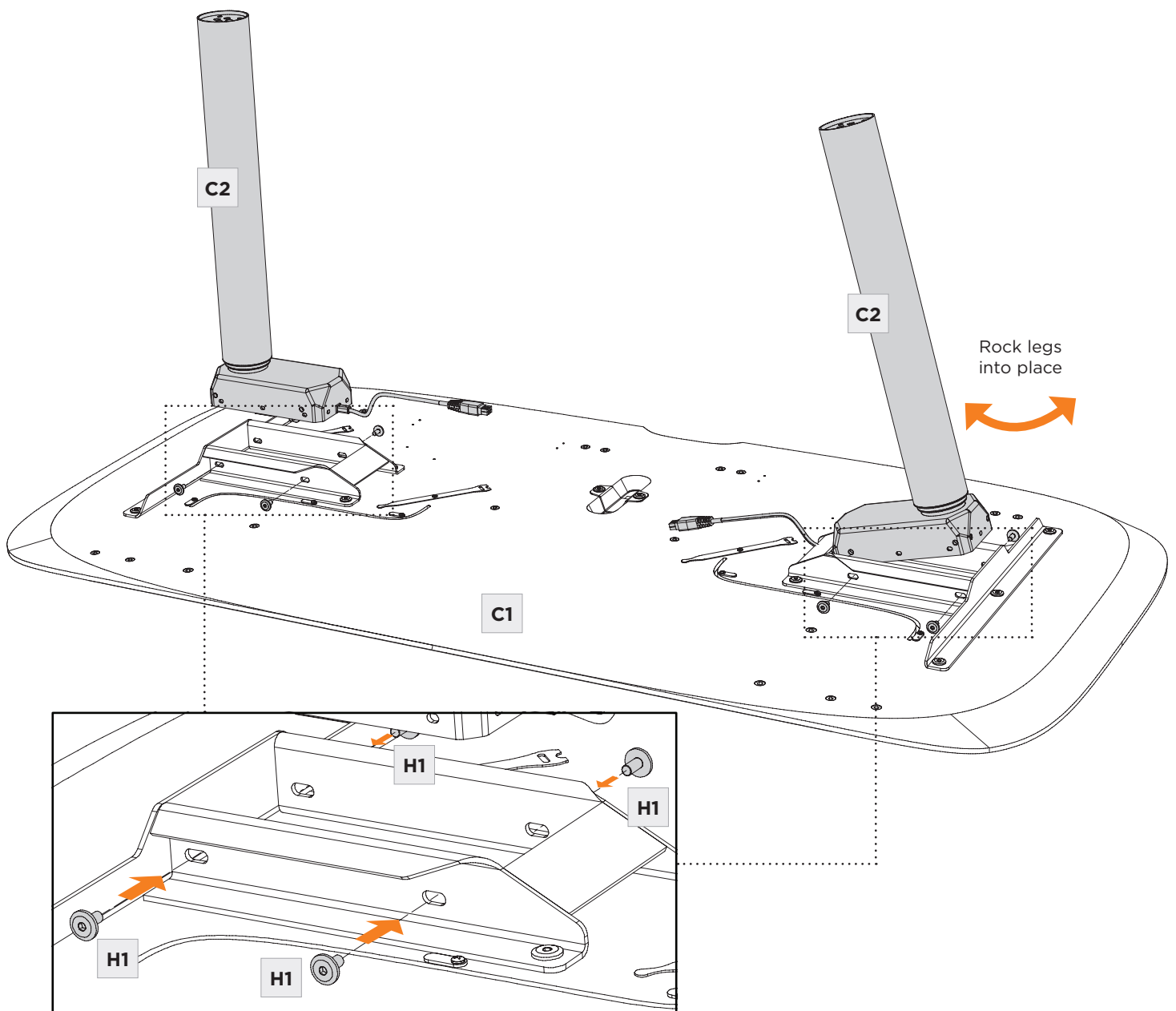

STEP 2. ATTACH KLEETS

ASSEMBLY

Attach **2 KLEETS (C3)** using **4 Wood Screws (H2)** going into 2 sets of pilot holes located as shown. Tighten with a **Phillips Screwdriver (not included)**.

	DESCRIPTION – PART #	QTY
	NOT INCLUDED Phillips Screwdriver	1
	WOOD SCREW – H2	4

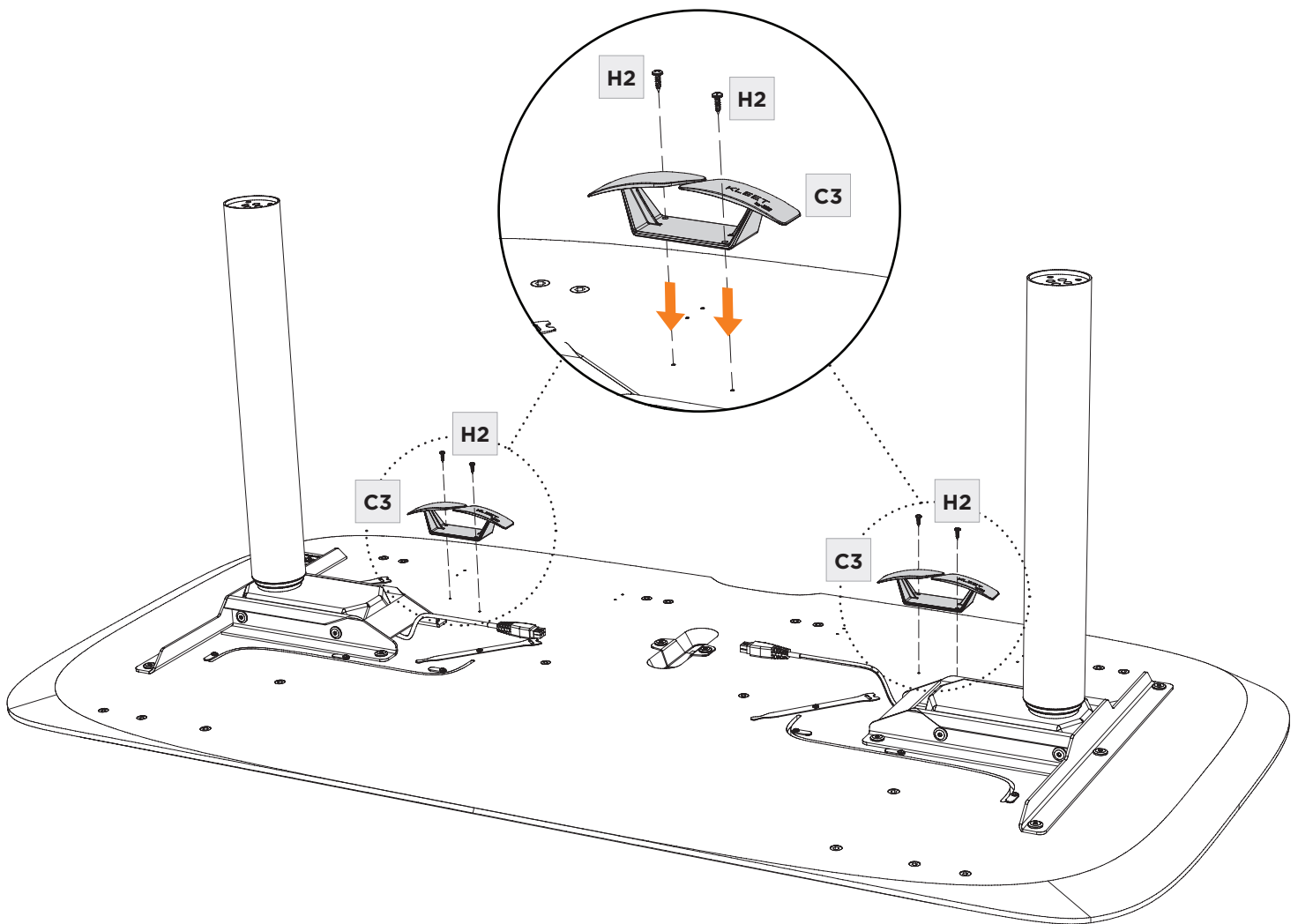

ASSEMBLY

STEP 3. ATTACH POWER STRIP, DIGITAL CONTROL PADDLE, CONTROL MODULE, AND HOOK

Attach the **Power Strip (C4)** on the desired side (left or right) using the included wood screws going into pre-drilled pilot holes. Tighten with a **Phillips Screwdriver**.

Attach the **Digital Control Paddle (C5)** on the desired side (left or right) using **2 Screws (H3)**. Tighten with **Phillips Screwdriver**.

Attach the **Hook (C7)** on the opposite side of the Control Paddle using **2 Screws (H3)**. Tighten with **Phillips Screwdriver**.

Position the **Control Module (C6)** in the middle of the **Top Panel (C1)** so that the Control Paddle socket—labeled **HS**—is facing the **Control Paddle (C5)** side. Fasten with **2 Screws (H3)**. Tighten with **Phillips Screwdriver**.

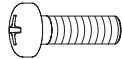
	DESCRIPTION – PART #	QTY
	NOT INCLUDED Phillips Screwdriver	1
	SCREW – H3	6

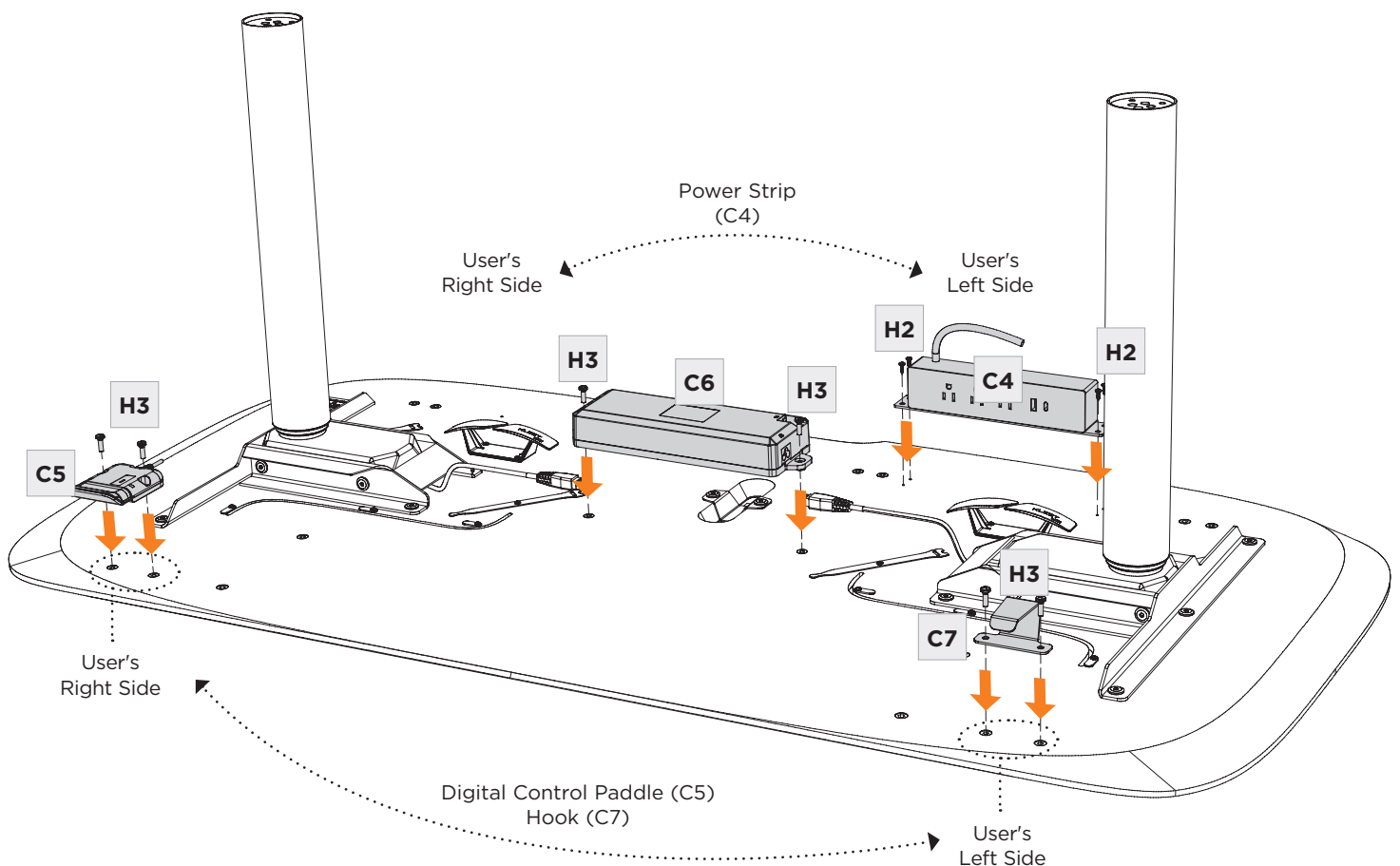

STEP 4. CONNECT PLUG & POWER CORD

ASSEMBLY

Route the Control Paddle cord into the groove in the **Top Panel (C1)**. Plug the end of the Control Paddle into the **HS socket** on the **Control Module (C6)**. Rotate the metal tabs near the groove to cover the cord and secure it in place.

Connect the **90 Degree Plug (C8)** to the Control Module socket labeled **M1**.

Connect the **Leg Cords** to the Control Module sockets labeled **M1** and **M2**. Use the hook and loop ties provided to gather loose cords.

Connect the **Power Cord (C9)** into the **Control Module (C6)** socket labeled **AC**.

Use the **KLEETS (C3)** to secure loose cords.

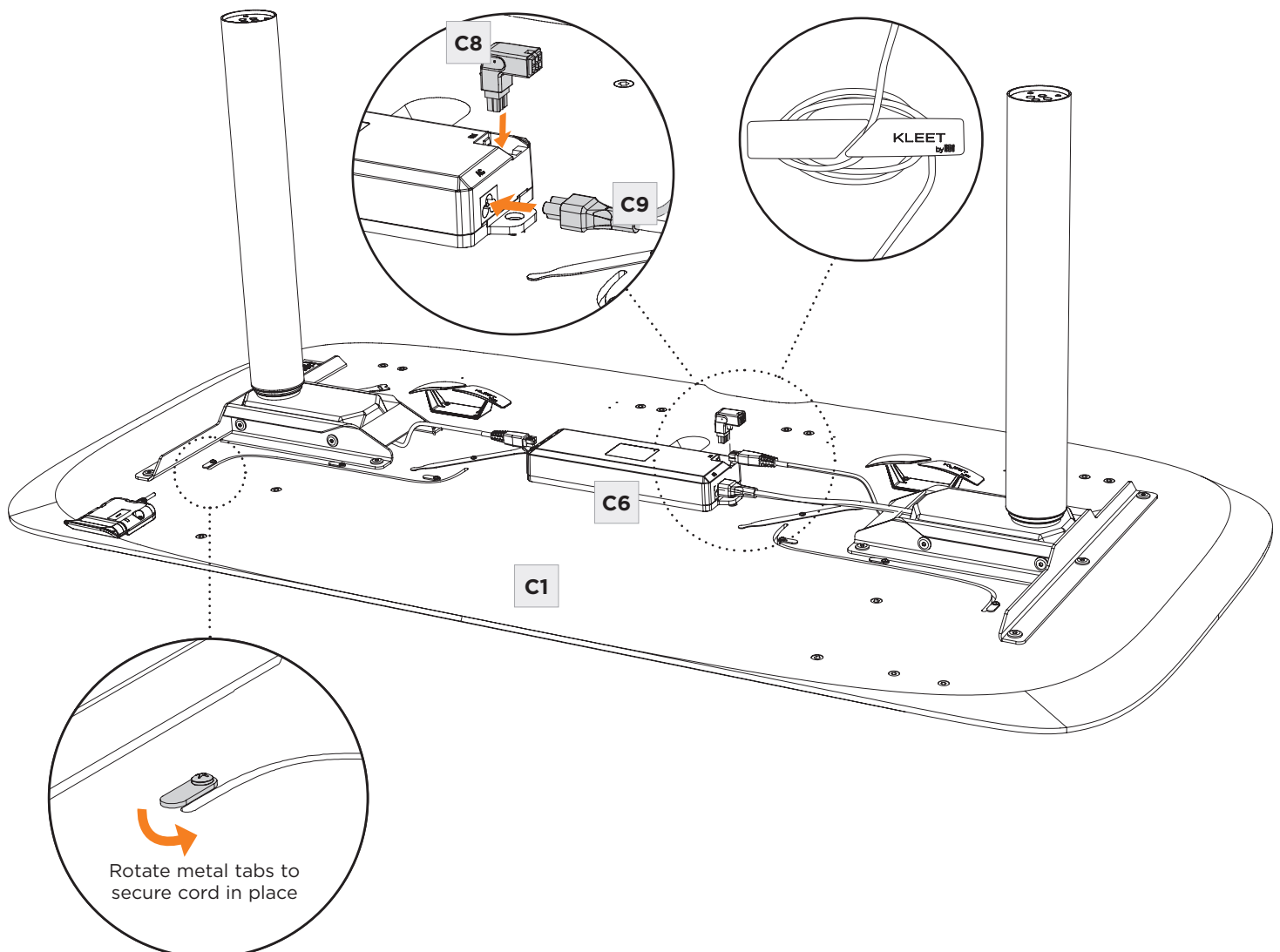

Attach both **Desk Feet (C10)** with the **8 Screws (H4)** using the **Hex Wrench (T1)**.

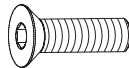
	DESCRIPTION – PART #	QTY
	HEX WRENCH – T1	1
	SCREW – H4	8

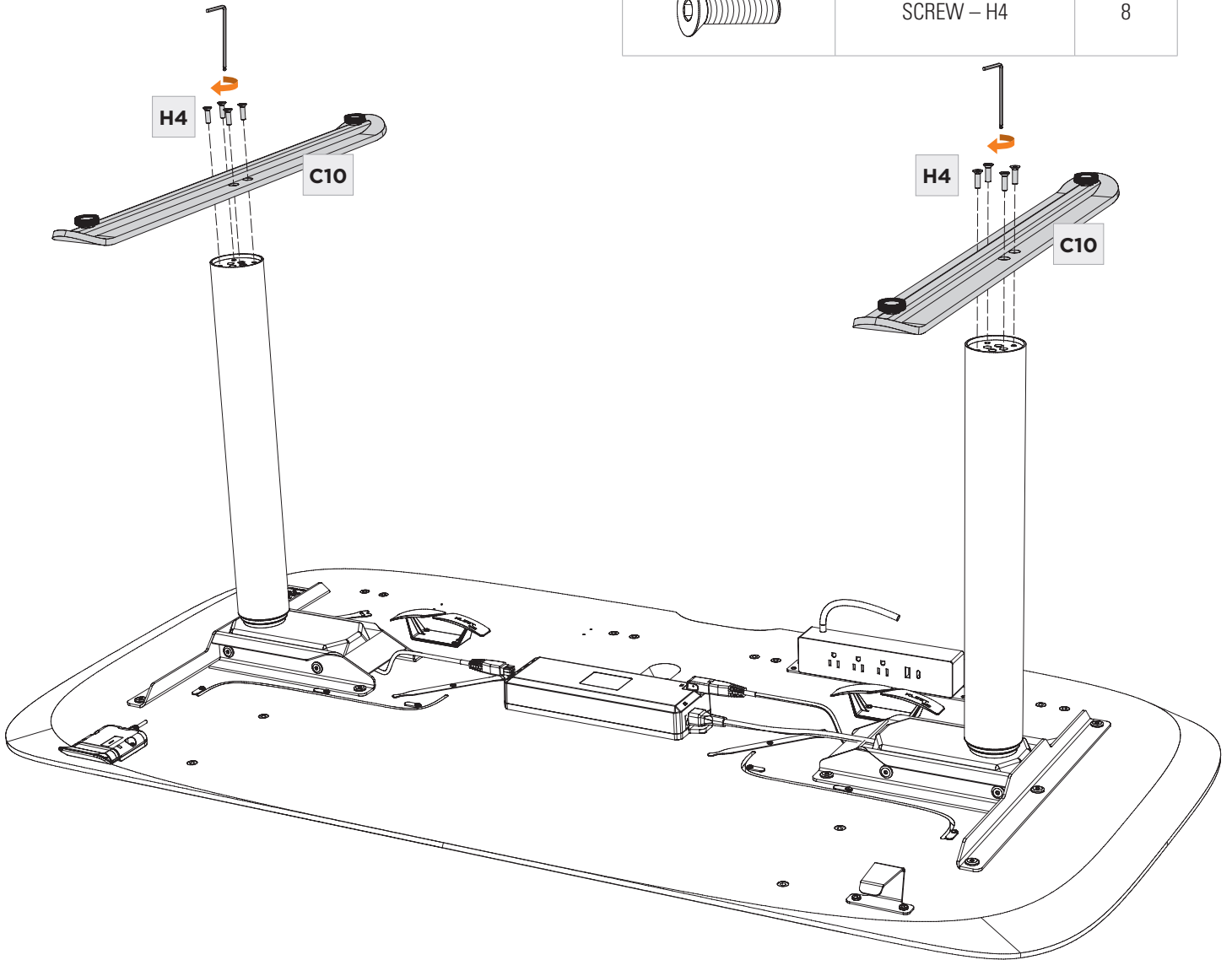

STEP 6. ATTACH WIRE CRADLE

2 PERSON TASK



ASSEMBLY

Attach the **Wire Cradle (C11)** to the **Top Panel (C1)** using **8 Screws (H1)**. Ensure the grooved side of the **Wire Cradle (C11)** is facing the front of the desk.

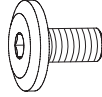
	DESCRIPTION – PART #	QTY
	HEX WRENCH – T1	1
	SCREW – H1	8

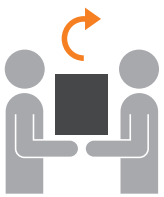
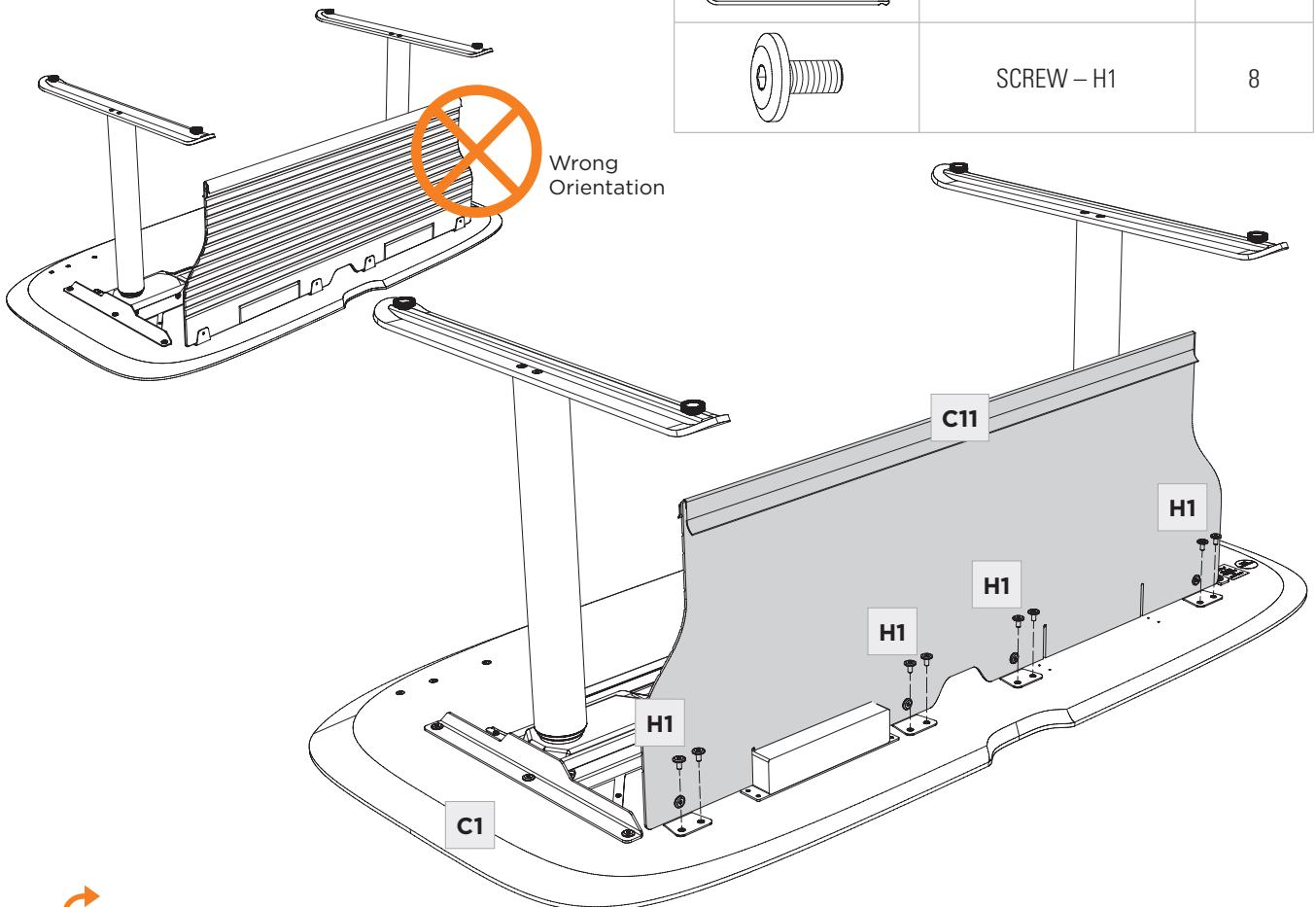

Plug the other end of the **Power Cord (C9)** into the nearest wall socket. Refer to the User Manual on Page 14 and follow the Reset Procedure. You may now adjust the height of your desk.

The **Wire Cradle (C11)** can act as a modesty panel if left hanging. You can also hide wires and electronics by swinging the Wire Wrap towards the front of the desk and hooking the Extrusion onto the front edge of the frames on the underside of the Top Panel.

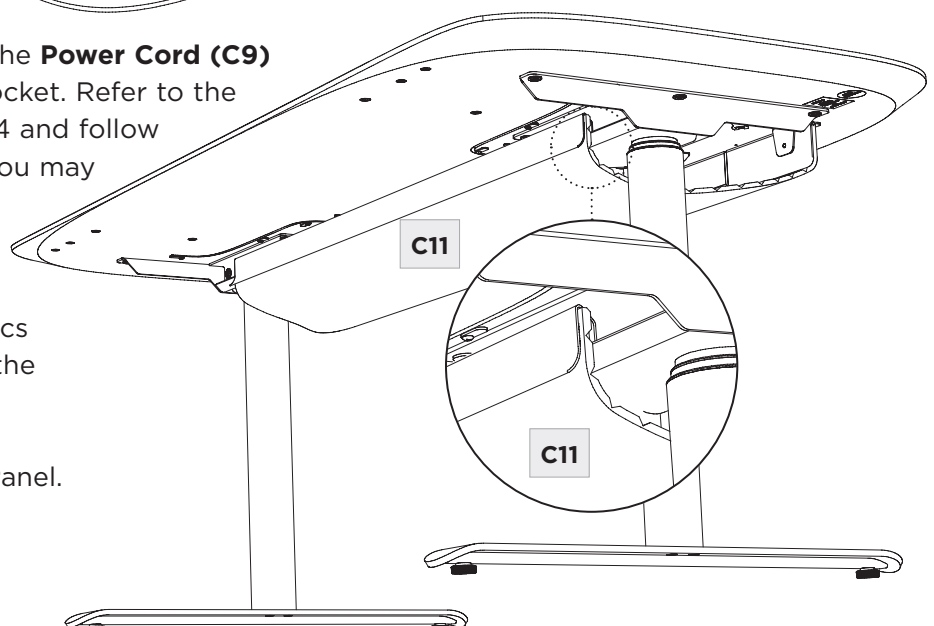

Install the **Grommet Lid (C12)** by placing it in the grommet slot. Slide it to its forward or rear position based on where you would like your wires to fall underneath your desk. Wires routed through the grommet will fall directly into the Wire Cradle.



REMOVE EXCESS LUBRICANT FROM LEGS

When new, the legs may have excess lubricant. Extend the legs to their highest position and wipe off excess lubricant with a clean, dry cloth or rag.

ADJUST LEVELERS

FINE TUNING

Levelers are integrated into each leg assembly and are accessed at the bottom of each leg. If your floor is uneven, you may extend one or more levelers to attain a level, stable position

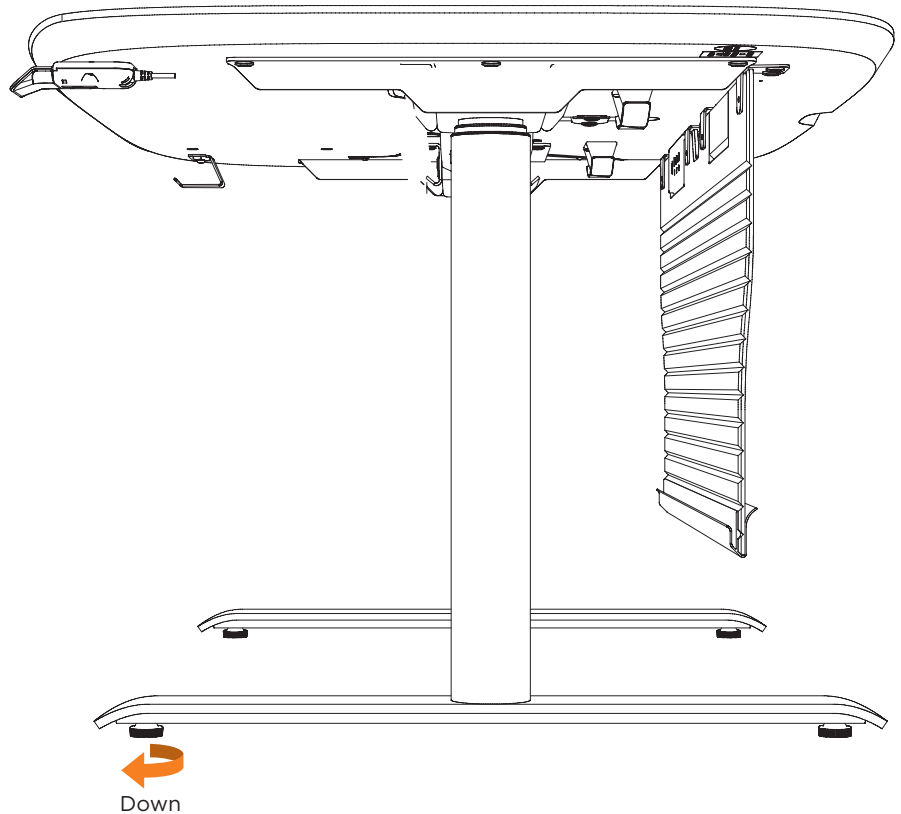

ATTACH A MONITOR ARM

FINE TUNING

The Soma Lift Desk is compatible with most third-party monitor arms. Attach your monitor arm anywhere along the back edge of the desk, ensuring the mount's base rests securely on the desk top, and not on the curved edge. Do not overtighten the monitor arm.

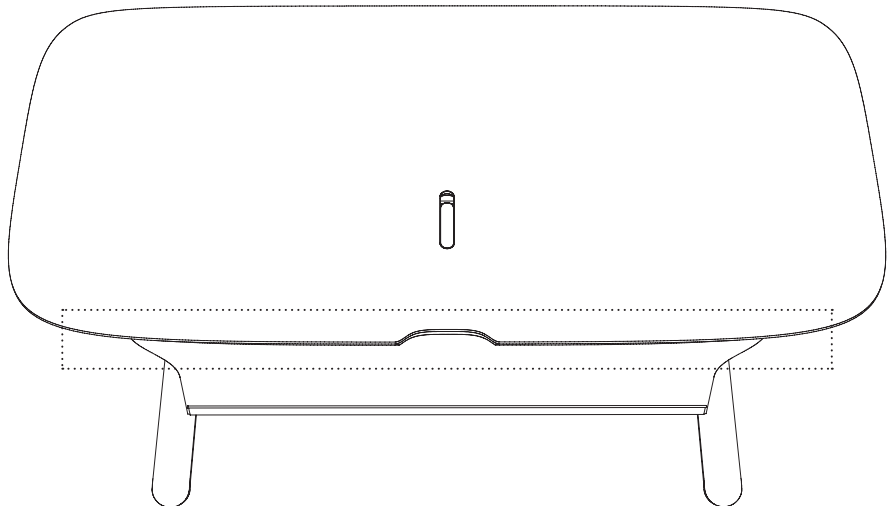

USING YOUR DIGITAL CONTROL PADDLE

Your desk's Control Paddle is designed to be intuitive and easy-to-use. Follow these steps to ensure that you are using your desk safely while getting the most out of its features.

SAFETY INFORMATION

- Ensure there are no obstructions in the desk's path (i.e. window sill, shelves)
- Position the desk slightly away from walls to avoid possible wall damage
- Be sure power cords and other wiring are long enough to reach the lowest & highest desk positions



GET TO KNOW YOUR NEW CONTROL PADDLE

The main area of the paddle is used to move your desk up or down. When programmed, a double-tap will take it to a saved seated or standing height (see below). There is a button on either side of the paddle. On the left is your Lock Button. On the right is your Menu Button that will guide you through specific user settings.



BEFORE USE: RESET YOUR CONTROL PADDLE

Resetting your control paddle calibrates the columns and control box. You can reset your control paddle at any time, it will not delete any saved height presets.

1. Press the paddle DOWN until the desk is in its lowest position. Release the paddle.
2. Press and hold the paddle DOWN again until the display reads "RESET". Release paddle.
3. Press and hold the paddle DOWN once again until the desk lowers a little more, slightly rises, then stops. Release paddle.

Your desk is now ready to use!

USING YOUR DIGITAL CONTROL PADDLE (CONTINUED)



ADJUSTING THE HEIGHT

Manually adjust the height by pressing or raising the control paddle until you achieve the desired height.

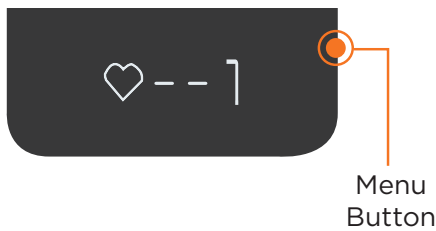

PROGRAMMING DESK HEIGHT PRESETS

1. To program your favorite seated and standing position, start by using the paddle to position the desktop to the desired height.
2. Press the right side menu button two times. A heart and a 1 or 2 will appear, signifying that your position has been set. 1 = seated position; 2 = standing position.

MOVING THE DESKTOP TO A SAVED HEIGHT

1. Tap the paddle to awaken it.
2. Double-tap up or down to move the desktop to the programmed height.



LOCKING CONTROL PADDLE

Press and hold the left side lock button until the display shows a lock symbol, approximately four seconds.

Repeat this step to unlock.

USING YOUR DIGITAL CONTROL PADDLE (CONTINUED)

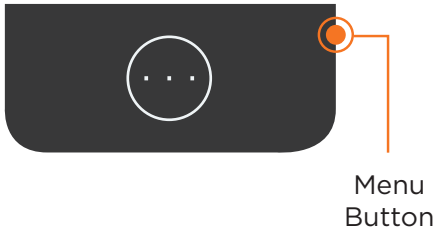

ADVANCED USER SETTINGS

For further optional customizations, you will need to access the Settings Menu. To access this menu, press and hold the Menu Button for approximately five seconds. Your settings options will appear. You can scroll through four menu screens by pressing the paddle.



SETTING THE MINIMUM OR MAXIMUM DESK HEIGHT

If you need to limit the range of movement of your desktop, this can be set using the first menu item.

1. Position your desktop at the height where you would like to stop your desk.
2. Hold the **Menu Button** for five seconds until the **Settings Menu** appears.
3. Press the **Menu Button** again, selecting menu 1 of 4, \updownarrow .
4. Use the paddle to move through the presented options:
 - MIN** Saves current desktop height as the minimum that the desk will not go below
 - MAX** Saves current desktop height as the maximum that the desk will not go above
 - OFF** Removes any programmed minimum or maximum positions
 - \leftarrow Returns you to the main menu
5. Press the **Menu Button** again to program your selection.

USING YOUR DIGITAL CONTROL PADDLE (CONTINUED)

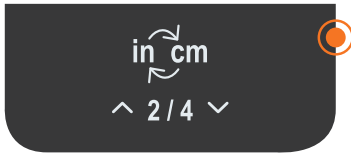

CHANGING YOUR DISPLAY FROM INCHES TO CENTIMETERS

If you would prefer to see your display in metric dimensions, you can change this setting while your desk is in **Reset Mode**.

1. Press the paddle DOWN until the desk is in its lowest position. Release the paddle.
2. Press and hold the paddle DOWN again until the display reads **RESET**. Release paddle.
3. While the paddle says RESET, press the **Menu Button** to access the **Settings Menu**.
4. Use the paddle to cycle through options, pressing the **Menu Button** again to access the **in ↔ cm** settings.
5. Use the paddle to select IN (inches), CM (centimeters) or ← to return you to the main menu.
6. Press the **Menu Button** again to program your selection.
7. Press and hold the paddle DOWN once more until the desk lowers slightly, slightly rises, then stops. You have now exited Reset Mode.



ADJUSTING COLLISION SENSITIVITY ON YOUR DESKTOP

Your desktop includes a built-in collision sensor, stopping your desk automatically if anything comes in contact with it while in motion. By default, your desk is set to MEDIUM sensitivity. You can change this setting while your desk is in **Reset Mode**.

1. Press the paddle DOWN until the desk is in its lowest position. Release the paddle.
2. Press and hold the paddle DOWN again until the display reads **RESET**. Release paddle.
3. While the paddle says RESET, press and hold the **Menu Button** for five seconds to access the **Settings Menu**.
4. Use the paddle to cycle through options, pressing the **Menu Button** again to access the **Collision Sensitivity** settings.
5. Use the paddle to cycle through LOW, MEDIUM and HIGH to select the level of sensitivity desired.
6. Press the **Menu Button** again to program your selection. This can take up to 15 seconds to reprogram.
7. Press and hold the paddle DOWN once more until the desk lowers slightly, slightly rises, then stops. You have now exited Reset Mode.

For more information, detailed specifications, and online assistance, visit www.bdiusa.com/soma-lift

CARE & MAINTENANCE

Your BDI furniture has been constructed with the finest materials, manufactured with care and is designed to last a lifetime. Regular care of your furniture will prolong your enjoyment and keep it looking its best. Here are some general tips for taking care of BDI furniture. Your surfaces may vary.

GLASS

Glass surfaces are maintained using household glass cleaner and a paper towel or cloth.

SATIN-ETCHED GLASS

This uniquely smooth-to-the-touch glass surface can be regularly maintained using household glass cleaner and a paper towel or cloth. Minor scratches or scuffs not eliminated using paper towel or cloth can usually be removed by using a 'Magic Eraser'. Magic Eraser is a melamine foam product available at any grocery store or home improvement center. Dampen the entire glass surface and the Magic Eraser, then rub the entire glass surface in broad, even strokes using moderate pressure. Clean and dry the surface with a paper towel. Check for results and repeat as necessary.

Any scratches or scuffing not eliminated by one of the above methods can often be addressed by 'refreshing' the glass. This is a process that should not be required more than once per 6-12 months. See this brief video for the simple method: www.bdiusa.com/glass

WOOD

Wood surfaces should be cleaned with a slightly damp (not saturated) cloth or paper towel. Do not use glass cleaner on wood. If moisture remains, dry the surface with another cloth. If needed, a gentle non-abrasive cleanser may be used, but be sure to wipe away all cleaner residue and dry the surface with a cloth.

BDI's wood finishes feature natural hardwood solids and veneers. Wood is a product of nature and—unlike man-made materials that can be manufactured to strict and consistent specifications—has natural imperfections that are part of its appeal and character. Every piece of wood differs from every other, even when coming from the very same tree. As such, variation in grain, texture and tone should be expected from one panel or piece of furniture to the next.

While BDI's stained wood finishes are stable in tone & appearance, all finishes are subject to some degree of discoloration with prolonged exposure to direct sunlight. Please take care to avoid positioning your BDI cabinet in any area with extensive direct sunlight. To learn more about the features of natural wood, visit www.bdiusa.com/wood

METAL, PORCELAIN, & PAINTED SURFACES

Surfaces should be cleaned with a slightly damp (not saturated) cloth or paper towel. If moisture remains, dry the surface with another cloth. If needed, a gentle non-abrasive cleanser may be used, but be sure to wipe away all cleaner residue and dry the surface with a cloth.

WARRANTY

BDI warrants to the original purchaser that for the below-stated warranty term, BDI will repair or replace any product, part, or component covered by this warranty that fails under normal use as a result of a defect in material or workmanship. BDI will repair or replace the aforementioned product, part or component with a comparable product, part or component. The decision to repair or replace will be at BDI's sole discretion.

BDI furniture is warranted for three (3) years from the date of purchase as shown on your sales receipt. The warranty period starts from the date of purchase. This warranty extends only to the original purchasers who acquire new products from BDI Authorized Resellers. Any product, part, or component must have been assembled, installed, used, and maintained according to BDI's published instructions to be eligible for warranty coverage. Any modification to the original product voids the warranty.

To view BDI's complete warranty information, visit www.bdiusa.com/warranty

PRODUCT REGISTRATION

Registering your new BDI product allows us to send you important product updates, service information, and helpful hints related to your BDI products. Register today, and you will be entered to win free a BINK table from BDI: www.bdiusa.com/register



BDIUSA.COM

These distinctive product configurations are protected by US and international patents, trade dress, and/or copyright laws. Soma & BDI are trademarks of Becker Designed, Inc. All rights reserved. ©2022, BDI | V.10.28.2022

Made in China